

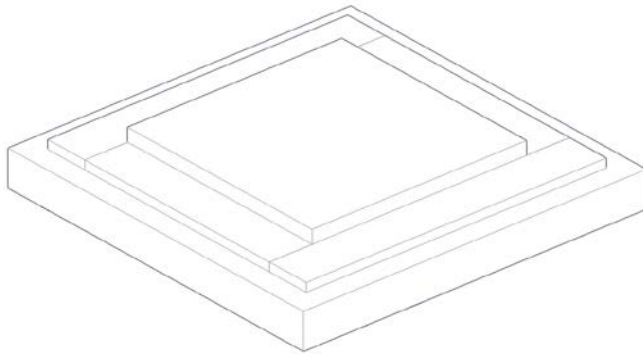

## ***PTFE SLIDING PLATES ASSEMBLY GUIDE***



There are two types of PTFE sliding plates. Here is represented the Option 1. In the Option 2 the base plate is drilled due to be fixed on site.

The PTFE plate is one side treated so it is stuck to the base plate and framed by welded flat bars.

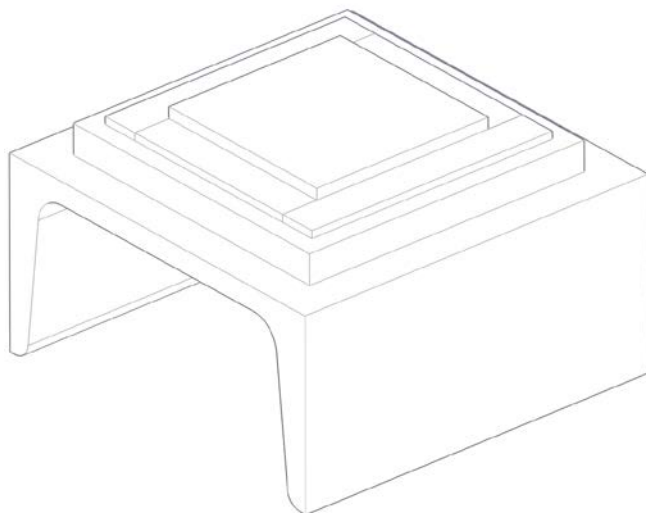
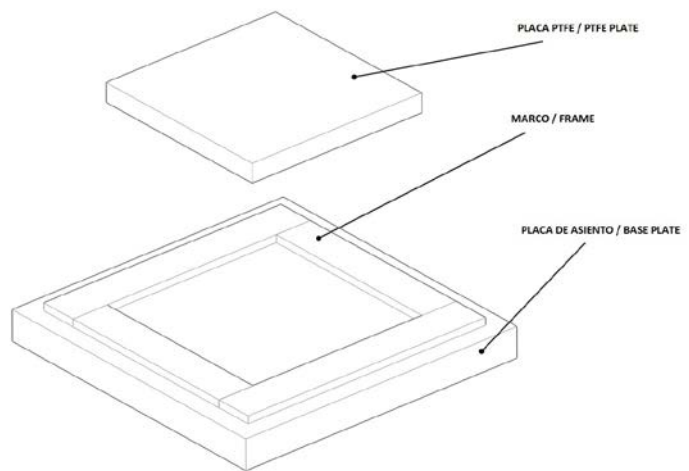

Weld the base plate in the right place following the engineering drawings and using discontinuous welding, trying to minimize the thermal supply due to do not unstuck the PTFE plate. When welding and painting the base plate, you must protect the PTFE plate preventing against spatters.

0	09/04/12	INFORMACIÓN	JCC	JMD
REV.	FECHA	EDITADO PARA	DIBUJ.	COMP.